

开槽盘头自攻螺钉

Slotted pan head tapping screws

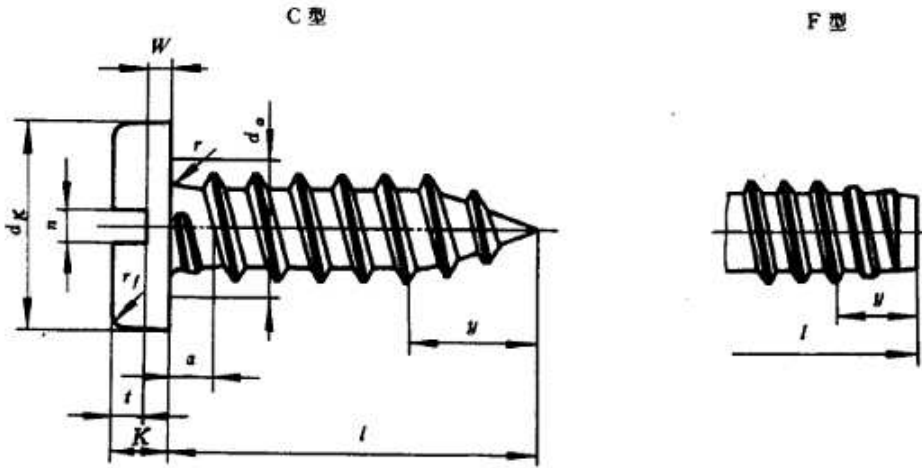

		mm								
螺纹规格		ST 2.2	ST 2.9	ST 3.5	ST 4.2	ST 4.8	ST 5.5	ST 6.3	ST 8	ST 9.5
P		0.8	1.1	1.3	1.4	1.6	1.8	1.8	2.1	2.1
a	max	0.8	1.1	1.3	1.4	1.6	1.8	1.8	2.1	2.1
d _s	max	2.8	3.5	4.1	4.9	5.5	6.3	7.1	9.2	10.7
d _r	max	4	5.6	7	8	9.5	11	12	16	20
	min	3.7	5.3	6.6	7.6	9.1	10.6	11.6	15.6	19.5
K	max	1.3	1.8	2.1	2.4	3	3.2	3.6	4.8	6
	min	1.1	1.6	1.9	2.2	2.7	2.9	3.3	4.5	5.7
n	公称	0.5	0.8	1	1.2	1.2	1.6	1.6	2	2.5
	min	0.56	0.86	1.06	1.26	1.26	1.66	1.66	2.06	2.56
	max	0.7	1	1.2	1.51	1.51	1.91	1.91	2.31	2.81
r	min	0.1	0.1	0.1	0.2	0.2	0.25	0.25	0.4	0.4
r _f	参考	0.6	0.8	1	1.2	1.5	1.6	1.8	2.4	3
t	min	0.5	0.7	0.8	1	1.2	1.3	1.4	1.9	2.4
W	min	0.5	0.7	0.8	0.9	1.2	1.3	1.4	1.9	2.4
y	(参考) C型	2	2.6	3.2	3.7	4.3	5	6	7.5	8
	F型	1.6	2.1	2.5	2.8	3.2	3.6	3.6	4.2	4.2

续表

mm

螺纹规格					ST 2.2	ST 2.9	ST 3.5	ST 4.2	ST 4.8	ST 5.5	ST 6.3	ST 8	ST 9.5
<i>l</i>													
公称	C型		F型										
	min	max	min	max									
4.5	3.7	5.3	3.7	4.5		—	—	—	—	—	—	—	—
6.5	5.7	7.3	5.7	6.5				—	—	—	—	—	—
9.5	8.7	10.3	8.7	9.5						—	—	—	—
13	12.2	13.8	12.2	13								—	—
16	15.2	16.8	15.2	16			商品						
19	18.2	19.8	18.2	19									
22	21.2	22.8	20.7	22					规格				
25	24.2	25.8	23.7	25							范围		
32	30.7	33.3	30.7	32									
38	36.7	39.3	36.7	38									
45	43.7	46.3	43.5	45									
50	48.7	51.3	48.5	50									

注：① *P* = 螺距。

② 表中带“—”标记的规格，不予制造。

螺 纹		GB 5280—85
机械性能		GB 3098.5—85
公 差	产品等级	A
	标 准	GB 3103.1—82
表面处理		镀锌钝化GB 5267—85
验收及包装		GB 90—85