

焊接六角螺母

Hexagon weld nuts



图 1

表 1

mm

螺纹规格 (D 或 D×P)		M4	M5	M6	M8	M10	M12	(M14)	M16
		—	—	—	M8×1	M10×1	M12×1.5	(M14×1.5)	M16×1.5
		—	—	—	—	(M10×1.25)	(M12×1.25)	—	—
d_2	max	4.6	5.75	6.75	8.75	10.8	13	15.1	17.3
	min	4	5	6	8	10	12	14	16
d_4	min	7.88	8.88	9.63	12.63	15.63	17.37	19.57	21.57
e	min	9.83	10.95	12.02	15.38	18.74	20.91	24.27	26.51
d_7	max	5.97	6.96	7.96	10.45	12.45	14.75	16.75	18.735
	min	5.885	6.87	7.87	10.34	12.34	14.64	16.64	18.605
d_3	max	6.18	7.22	8.22	10.77	12.77	15.07	17.07	19.13
	min	6	7	8	10.5	12.5	14.8	16.8	18.8
h_1	max	0.65	0.70	0.75	0.90	1.15	1.40	1.80	1.80
	min	0.55	0.60	0.60	0.75	0.95	1.20	1.60	1.60
h_2	max	0.35	0.40	0.40	0.50	0.65	0.80	1.0	1.0
	min	0.25	0.30	0.30	0.35	0.50	0.60	0.80	0.80
b	max	1	1	1.12	1.25	1.55	1.55	1.9	1.9
	min	0.6	0.6	0.68	0.75	0.95	0.95	1.1	1.1
m	max	3.5	4	5	6.5	8	10	11	13
	min	3.2	3.7	4.7	6.14	7.64	9.64	10.3	12.3
s	max	9	10	11	14	17	19	22	24
	min	8.78	9.78	10.73	13.73	16.73	18.67	21.67	23.67

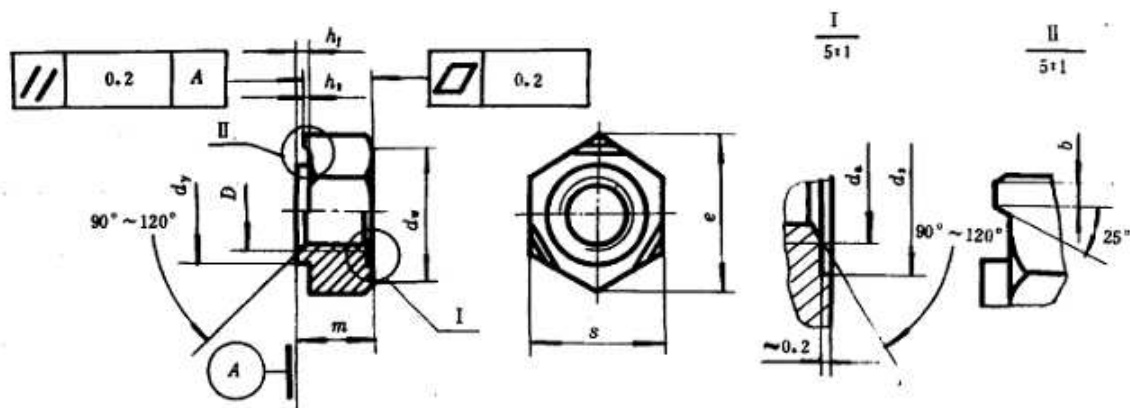
注：尽可能不采用括号内的规格。