

# 开槽机螺钉

JIS  
B1101 - 1996

附表 1 盘头螺钉

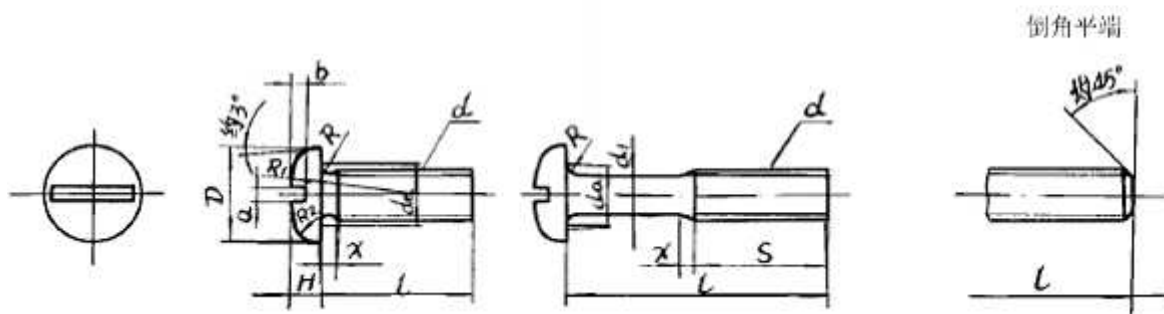

单位: mm

螺纹公称直径 ( $d$ )	螺距 $p$	$D$		$H$		$R_1$	$R_2$	$a$		$b$		$R$	$da$	$E^{(16)}$	$F^{(16)}$	$G$
		基本尺寸	偏差	基本尺寸	偏差	约	约	基本尺寸	偏差	基本尺寸	偏差	最小	最大	最大	最大	最大
M1	0.25	2	$\begin{smallmatrix} 0 \\ -0.3 \end{smallmatrix}$	0.65	$\pm 0.1$	3	0.3	0.32	$\begin{smallmatrix} +0.1 \\ 0 \end{smallmatrix}$	0.3	$\pm 0.05$	0.1	1.4	0.1	0.05	
M1.2	0.25	2.3		0.8		3.5	0.4	0.32		0.4		0.1	1.6	0.1	0.05	
(M1.4)	0.3	2.6	$\begin{smallmatrix} 0 \\ -0.4 \end{smallmatrix}$	0.9		3.7	0.5	0.32		0.5	0.1	1.8	0.15	0.1		
M1.6	0.35	3		1		4	0.5	0.4		0.55	0.1	2	0.15	0.1		
*(M1.7)	0.35	3.2		1.1		4.2	0.6	0.4		0.6	0.1	2.1	0.15	0.1		
M2	0.4	3.5		1.3		4.5	0.7	0.6		0.7	0.1	2.6	0.15	0.1		
(M2.2)	0.45	4		1.5		5	0.8	0.6		0.8	0.1	2.8	0.2	0.15		
*(M2.3)	0.4	4		1.5		5	0.8	0.6		0.8	0.1	2.9	0.2	0.15		
M2.5	0.45	4.5		1.7		6	0.9	0.8		0.9	0.1	3.1	0.2	0.15		
*(M2.6)	0.45	4.5		1.7		6	0.9	0.8		0.9	0.1	3.2	0.2	0.15		
M3×0.5	0.5	5.5	$\begin{smallmatrix} 0 \\ -0.5 \end{smallmatrix}$	2	7	1.1	0.8	1.1	0.1	3.6	0.25	0.2				
(M3.5)	0.6	6		2.3	8	1.3	1	1.25	0.1	4.1	0.25	0.2				
M4×0.7	0.7	7		2.6	9	1.5	1	1.4	0.2	4.7	0.3	0.2				
(M4.5)	0.75	8	$\begin{smallmatrix} 0 \\ -0.6 \end{smallmatrix}$	2.9	11	1.7	1	1.6	0.2	5.2	0.35	0.25				
M5×0.8	0.8	9		3.3	12	1.9	1.2	1.8	0.2	5.7	0.35	0.25				
M6	1	10.5	$\begin{smallmatrix} 0 \\ -0.7 \end{smallmatrix}$	3.9	14	2.3	1.2	2.1	0.25	6.8	0.4	0.3				
M8	1.25	14		5.2	18	3	1.6	2.8	0.4	9.2	0.5	0.4				

附表2 沉头螺钉

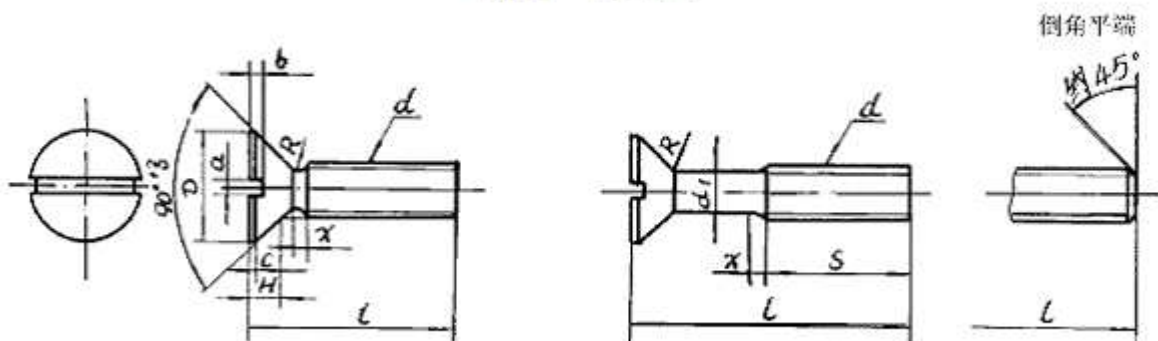

单位: mm

螺纹公称直径 ( $d$ )	螺距 $P$	$D$		$H^{(17)}$		$C$	$a$		$b$		$R$	$E^{(16)}$ 最大	$F^{(16)}$ 最大	$G$ 最大
		基本尺寸	偏差	基本尺寸	偏差		约	基本尺寸	偏差	基本尺寸				
M1	0.25	2		0.6		0.1	0.32		0.25		0.1	0.1	0.05	
M1.2	0.25	2.4	$^{-0.3}$	0.7	$^{-0.1}$	0.1	0.32	$^{+0.1}$ $_0$	0.3	$\pm 0.05$	0.12	0.1	0.05	
(M1.4)	0.3	2.8		0.85		0.15	0.32		0.3		0.14	0.15	0.1	
M1.6	0.35	3.2		0.95		0.15	0.4		0.35		0.16	0.15	0.1	
* (M1.7)	0.35	3.4		1		0.15	0.4		0.4		0.17	0.15	0.1	
M2	0.4	4		1.2		0.2	0.6		0.5		0.2	0.15	0.1	
(M2.2)	0.45	4.4	$^{-0.4}$	1.3	$^{-0.2}$	0.2	0.6		0.5	$\pm 0.1$	0.22	0.2	0.15	
* (M2.3)	0.4	4.6		1.35		0.2	0.6		0.5		0.23	0.2	0.15	
M2.5	0.45	5		1.45		0.2	0.8	$^{+0.15}$ $_0$	0.6		0.25	0.2	0.15	
* (M2.6)	0.45	5.2		1.5		0.2	0.8		0.6		0.26	0.2	0.15	
M3×0.5	0.5	6		1.75		0.25	0.8		0.7		0.3	0.25	0.2	
(M3.5)	0.6	7	$^{-0.5}$	2		0.25	1		0.8	$\pm 0.15$	0.35	0.25	0.2	
M4×0.7	0.7	8		2.3	$^{-0.3}$	0.3	1		0.9		0.4	0.3	0.2	
(M4.5)	0.75	9	$^{-0.6}$	2.55		0.3	1		1	$\pm 0.2$	0.45	0.35	0.25	
M5×0.8	0.8	10		2.8		0.3	1.2		1.1		0.5	0.35	0.25	
M6	1	12	$^{-0.7}$	3.4	$^{-0.4}$	0.4	1.2	$^{+0.2}$ $_0$	1.4	$\pm 0.25$	0.6	0.4	0.3	
M8	1.25	16	$^{-0.8}$	4.4		0.4	1.6		1.8	$\pm 0.3$	0.8	0.5	0.4	

附表3 半沉头螺钉

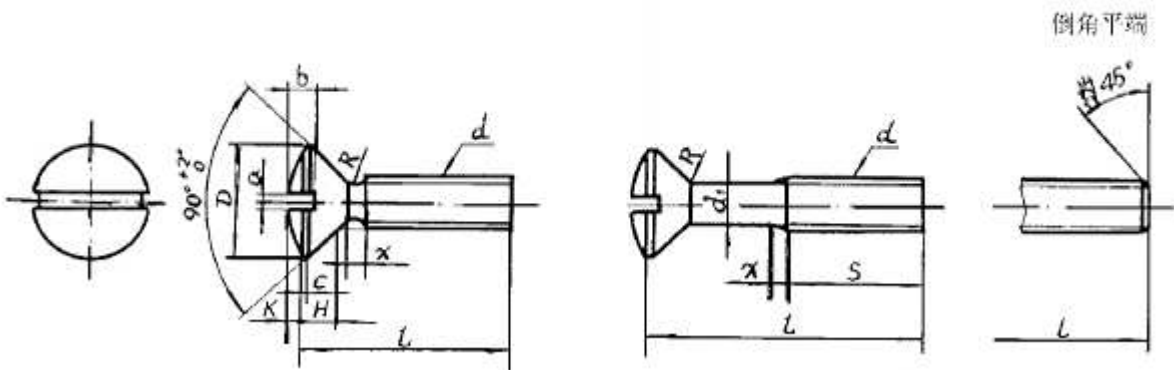

单位: mm

螺纹公称直径 ( $d$ )	螺距 $P$	$D$		$H^{(D)}$		$C$	$K$	$H+K$		$a$		$b$		$R$	$E^{(26)}$	$F^{(16)}$	$G$
		基本尺寸	偏差	基本尺寸	偏差			约	约	基本尺寸	偏差	基本尺寸	偏差				
M1	0.25	2		0.6		0.1	0.2	0.8	$0_{-0.2}^0$	0.32		0.35		0.1	0.1	0.05	
M1.2	0.25	2.4	$0_{-0.3}^0$	0.7	$0_{-0.1}^0$	0.1	0.3	1		0.32	$0_{+0.1}^0$	0.45		0.12	0.1	0.05	
(M1.4)	0.3	2.8		0.85		0.15	0.3	1.15		0.32		0.5	$\pm 0.1$	0.14	0.15	0.1	
M1.6	0.35	3.2		0.95		0.15	0.35	1.3	$0_{-0.3}^0$	0.4		0.55		0.16	0.15	0.1	
* (M1.7)	0.35	3.4		1		0.15	0.4	1.4		0.4		0.6		0.17	0.15	0.1	
M2	0.4	4		1.2		0.2	0.4	1.6		0.6		0.7		0.2	0.15	0.1	
(M2.2)	0.45	4.4	$0_{-0.4}^0$	1.3	$0_{-0.2}^0$	0.2	0.5	1.8		0.6		0.8		0.22	0.2	0.15	
* (M2.3)	0.4	4.6		1.35		0.2	0.5	1.85	$0_{-0.4}^0$	0.6		0.8	$\pm 0.15$	0.23	0.2	0.15	
M2.5	0.45	5		1.45		0.2	0.55	2		0.8	$0_{+0.15}^0$	0.9		0.25	0.2	0.15	
* (M2.6)	0.45	5.2		1.5		0.2	0.6	2.1		0.8		0.9		0.26	0.2	0.15	
M3×0.5	0.5	6		1.75		0.25	0.7	2.45		0.8		1.1		0.3	0.25	0.2	
(M3.5)	0.6	7	$0_{-0.5}^0$	2		0.25	0.8	2.8		1		1.2	$\pm 0.2$	0.35	0.25	0.2	
M4×0.7	0.7	8		2.3	$0_{-0.3}^0$	0.3	0.9	3.2	$0_{-0.5}^0$	1		1.4	$\pm 0.25$	0.4	0.3	0.2	
(M4.5)	0.75	9		2.55		0.3	1	3.55		1		1.5		0.45	0.35	0.25	
M5×0.8	0.8	10	$0_{-0.6}^0$	2.8		0.3	1.2	4		1.2		1.7	$\pm 0.3$	0.5	0.35	0.25	
M6	1	12	$0_{-0.7}^0$	3.4	$0_{-0.4}^0$	0.4	1.4	4.8	$0_{-0.6}^0$	1.2	$0_{+0.2}^0$	2.1	$\pm 0.4$	0.6	0.4	0.3	
M8	1.25	16	$0_{-0.8}^0$	4.4		0.4	1.8	6.2		1.6		2.7	$\pm 0.5$	0.8	0.5	0.4	

附表4 扁圆头螺钉

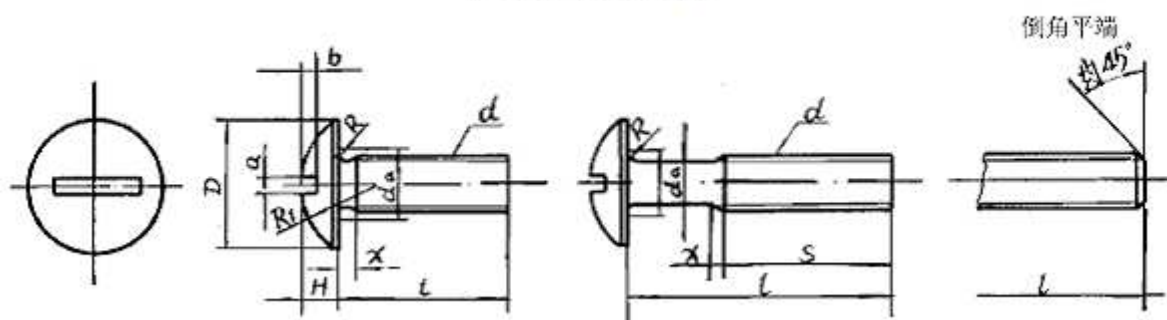

单位: mm

螺纹公称直径 ( $d$ )	螺距 $p$	$D$		$H$		$R$	$a$		$b$		$R$	$da$	$E^{(16)}$	$F^{(16)}$	$G$
		基本尺寸	偏差	基本尺寸	偏差	约	基本尺寸	偏差	基本尺寸	偏差	最小	最大	最大	最大	最大
M2	0.4	4.5		1.2		3	0.6		0.6		0.1	2.6	0.15	0.1	
(M2.2)	0.45	5		1.3		3.2	0.6		0.65		0.1	2.8	0.2	0.15	
*(M2.3)	0.4	5.2	$^{0}_{-0.4}$	1.4	$\pm 0.1$	3.4	0.6		0.7	$\pm 0.1$	0.1	2.9	0.2	0.15	
M2.5	0.45	5.7		1.5		3.7	0.8		0.75		0.1	3.1	0.2	0.15	
*(M2.6)	0.45	5.9		1.6		3.9	0.8	$^{+0.15}_{0}$	0.8		0.1	3.2	0.2	0.15	
M3×0.5	0.5	6.9		1.9		4.6	0.8		0.95	$\pm 0.15$	0.1	3.6	0.25	0.2	
(M3.5)	0.6	8.1	$^{0}_{-0.5}$	2.2		5.4	1		1.1		0.1	4.1	0.25	0.2	$2^{\circ}$
M4×0.7	0.7	9.4		2.5	$\pm 0.15$	6.1	1		1.25	$\pm 0.2$	0.2	4.7	0.3	0.2	
(M4.5)	0.75	10.6	$^{0}_{-0.6}$	2.8		6.9	1		1.4		0.2	5.2	0.35	0.25	
M5×0.8	0.8	11.8		3.1		7.7	1.2		1.6	$\pm 0.25$	0.2	5.7	0.35	0.25	
M6	1	14	$^{0}_{-0.7}$	3.7		9.1	1.2	$^{+0.2}_{0}$	1.9	$\pm 0.3$	0.25	6.8	0.4	0.3	
M8	1.25	17.8	$^{0}_{-0.8}$	4.8	$\pm 0.2$	11.7	1.6		2.4	$\pm 0.4$	0.4	9.2	0.5	0.4	

附表5 球面扁圆柱头

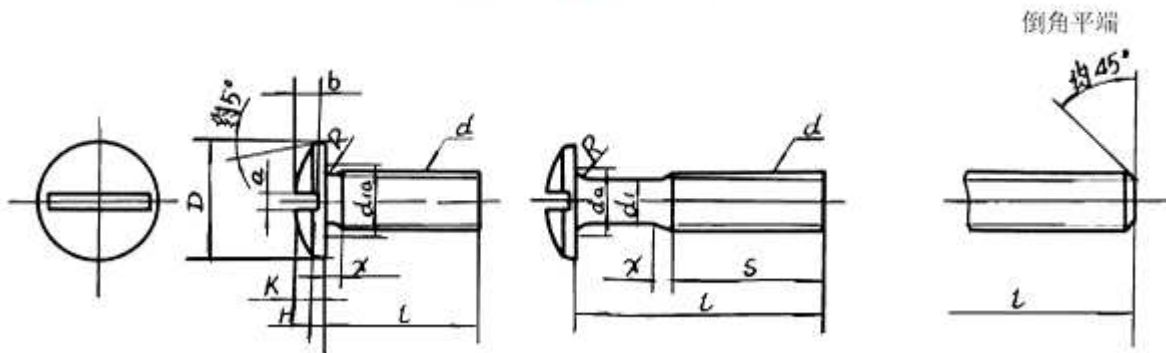

单位: mm

螺纹公称直径 ( $d$ )	螺距 $P$	$D$		$H$		$K$		$H+K$		$a$		$b$		$R$	$d_a$	$E^{(36)}$	$F^{(36)}$	$G$
		基本尺寸	偏差	约	基本尺寸	偏差	基本尺寸	偏差	基本尺寸	偏差	基本尺寸	偏差	最小					
M2	0.4	4.3		0.85	0.35			1.2		0.6		0.65		0.1	2.6	0.15	0.1	
(M2.2)	0.45	4.7		0.9	0.4			1.3		0.6		0.7	$\pm 0.1$	0.1	2.8	0.2	0.15	
* (M2.3)	0.4	4.9	$-0.4$	1	0.4	$\pm 0.1$		1.4	$\pm 0.15$	0.6		0.7		0.1	2.9	0.2	0.15	
M2.5	0.45	5.3		1	0.5			1.5		0.8		0.8		0.1	3.1	0.2	0.15	
* (M2.6)	0.45	5.5		1.1	0.5			1.6		0.8	$+0.15$	0.85	$\pm 0.15$	0.1	3.2	0.2	0.15	
M3×0.5	0.5	6.3		1.3	0.6			1.9		0.8		1		0.1	3.6	0.25	0.2	
(M3.5)	0.6	7.3	$-0.5$	1.5	0.7			2.2		1		1.15	$\pm 0.2$	0.1	4.1	0.25	0.2	
M4×0.7	0.7	8.3		1.7	0.8			2.5		1		1.3		0.2	4.7	0.3	0.2	
(M4.5)	0.75	9.3		1.9	0.9	$\pm 0.15$		2.8	$\pm 0.2$	1		1.5	$\pm 0.25$	0.2	5.2	0.35	0.25	
M5×0.8	0.8	10.3	$-0.6$	2.1	1			3.1		1.2		1.7		0.2	5.7	0.35	0.25	
M6	1	12.4	$-0.7$	2.4	1.3			3.7		1.2	$+0.2$	2	$\pm 0.3$	0.25	6.8	0.4	0.3	
M8	1.25	16.4	$-0.8$	3.1	1.7	$\pm 0.2$		4.8	$\pm 0.3$	1.6		2.8	$\pm 0.5$	0.4	9.2	0.5	0.4	

附表6 圆头螺钉

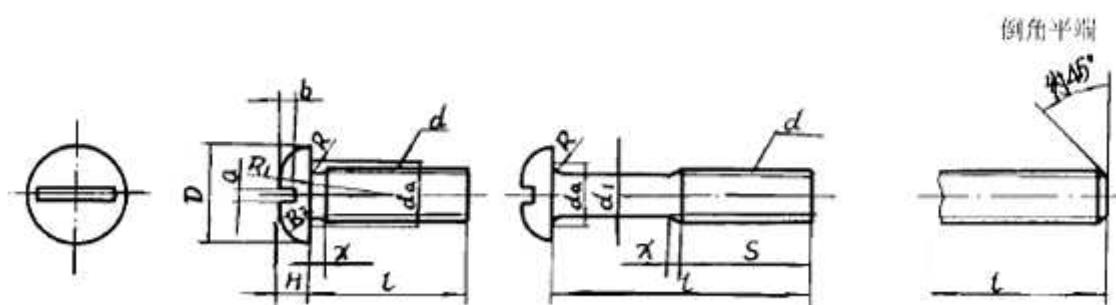

单位: mm

螺纹公称直径 ( $d$ )	螺距 $P$	$D$		$H$		$R_1$	$R_2$	$a$		$b$		$R$	$d_a$	$E^{(16)}$	$F^{(16)}$	$G$
		基本尺寸	偏差	基本尺寸	偏差	约	约	基本尺寸	偏差	基本尺寸	偏差	最小	最大	最大	最大	最大
M1	0.25	2		0.8		1.2	0.7	0.32		0.45		0.1	1.4	0.1	0.05	
M1.2	0.25	2.3	$-0.3$	0.9		1.4	0.8	0.32	$+0.1$	0.5		0.1	1.6	0.1	0.05	
(M1.4)	0.3	2.6		1		1.6	0.9	0.32		0.6	$\pm 0.1$	0.1	1.8	0.15	0.1	
M1.6	0.35	3		1.1		1.8	1	0.4		0.65		0.1	2	0.15	0.1	
* (M1.7)	0.35	3.2		1.2	$\pm 0.1$	1.9	1.1	0.4		0.7		0.1	2.1	0.15	0.1	
M2	0.4	3.5		1.3		2.1	1.2	0.6		0.8		0.1	2.6	0.15	0.1	
(M2.2)	0.45	4	$-0.4$	1.5		2.4	1.3	0.6		0.9		0.1	2.8	0.2	0.15	
* (M2.3)	0.4	4		1.5		2.4	1.3	0.6		0.9	$\pm 0.15$	0.1	2.9	0.2	0.15	
M2.5	0.45	4.5		1.7		2.7	1.5	0.8	$+0.15$	1		0.1	3.1	0.2	0.15	⌋
* (M2.6)	0.45	4.5		1.7		2.7	1.5	0.8		1		0.1	3.2	0.2	0.15	
M3 × 0.5	0.5	5.5		2		3.3	1.8	0.8		1.2	$\pm 0.2$	0.1	3.6	0.25	0.2	
(M3.5)	0.6	6	$-0.5$	2.3		3.6	2	1		1.4		0.1	4.1	0.25	0.2	
M4 × 0.7	0.7	7		2.6	$\pm 0.15$	4.2	2.3	1		1.6	$\pm 0.25$	0.2	4.7	0.3	0.2	
(M4.5)	0.75	8		3		4.8	2.7	1		1.9	$\pm 0.3$	0.2	5.2	0.35	0.25	
M5 × 0.8	0.8	9	$-0.6$	3.4		5.4	3	1.2		2.1		0.2	5.7	0.35	0.25	
M6	1	10.5	$-0.7$	4	$\pm 0.2$	6.3	3.5	1.2	$+0.2$	2.5	$\pm 0.4$	0.25	6.8	0.4	0.3	
M8	1.25	14	$-0.8$	5.4		8.4	4.6	1.6		3.3	$\pm 0.5$	0.4	9.2	0.5	0.4	

附表7 圆柱头螺钉

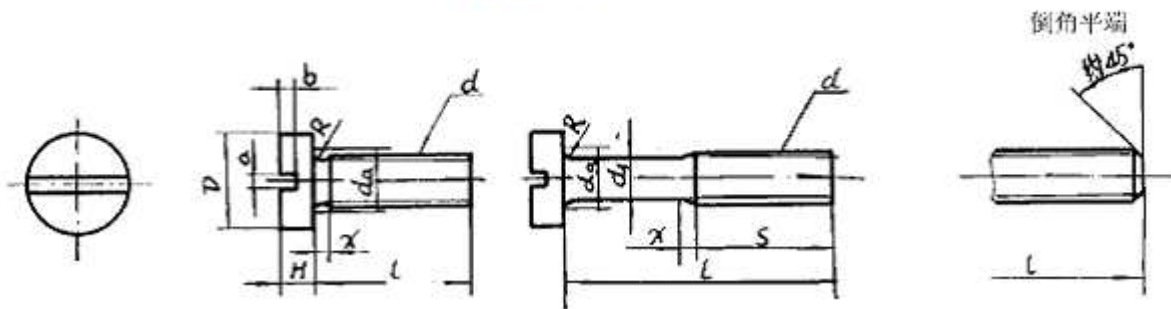

单位: mm

螺纹公称直径 ( <i>d</i> )	螺距 <i>p</i>	<i>D</i>		<i>H</i>		<i>a</i>		<i>b</i>		<i>R</i>	<i>da</i>	<i>E<sup>(16)</sup></i>	<i>F<sup>(16)</sup></i>	<i>G</i>
		基本尺寸	偏差	基本尺寸	偏差	基本尺寸	偏差	基本尺寸	偏差	最小	最大	最大	最大	最大
M1	0.25	2	0 -0.3	0.65	±0.1	0.32	+0.1 0	0.3	±0.05	0.1	1.4	0.1	0.05	J
M1.2	0.25	2.3		0.8		0.32		0.4		0.1	1.6	0.1	0.05	
(M1.4)	0.3	2.6	0 -0.4	0.9		0.32	+0.15 0	0.5	±0.1	0.1	1.8	0.15	0.1	
M1.6	0.35	3		1		0.4		0.55		0.1	2	0.15	0.1	
* (M1.7)	0.35	3.2		1.1		0.4		0.6		0.1	2.1	0.15	0.1	
M2	0.4	3.5		1.3		0.6		0.7		0.1	2.6	0.15	0.1	
(M2.2)	0.45	4		1.5		0.6		0.8		0.1	2.8	0.2	0.15	
* (M2.3)	0.4	4		1.5		0.6		0.8		0.1	2.9	0.2	0.15	
M2.5	0.45	4.5		1.7		0.8		0.9		0.1	3.1	0.2	0.15	
* (M2.6)	0.45	4.5		1.7		0.8		0.9		±0.15	0.1	3.2	0.2	
M3×0.5	0.5	5.5	0 -0.5	2	±0.15	0.8	1.1	±0.2	0.1	3.6	0.25	0.2		
(M3.5)	0.6	6		2.3		1			1.25	0.1	4.1	0.25	0.2	
M4×0.7	0.7	7		2.6		1			1.4	0.2	4.7	0.3	0.2	
(M4.5)	0.75	8	0 -0.6	2.9	±0.2	1	1.6	±0.25	0.2	5.2	0.35	0.25		
M5×0.8	0.8	9		3.3		1.2			1.8	0.2	5.7	0.35	0.25	
M6	1	10.5	0 -0.7	3.9	±0.2	1.2	+0.2 0	±0.3	0.25	6.8	0.4	0.3		
M8	1.25	14		5.2		1.6			2.8	±0.5	0.4	9.2	0.5	0.4

附表8 球面圆柱头螺钉

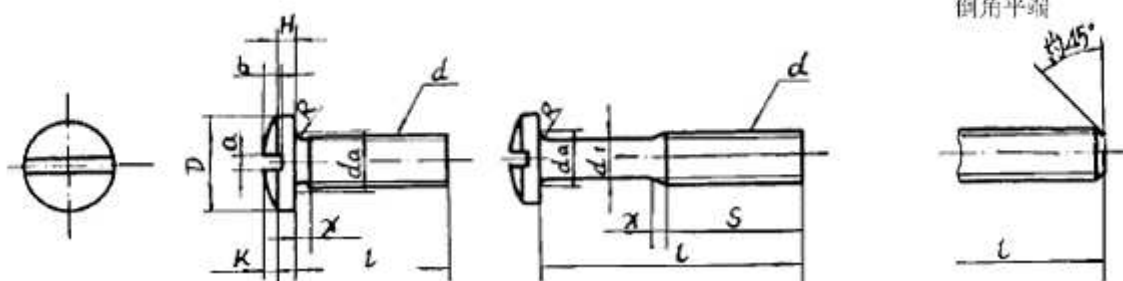



单位: mm

螺纹公称直径 ( <i>d</i> )	螺距 <i>P</i>	<i>D</i>		<i>H</i>		<i>K</i>		<i>H + K</i>		<i>a</i>		<i>b</i>		<i>R</i>	<i>d<sub>a</sub></i>	<i>E<sup>(26)</sup></i>	<i>F<sup>(26)</sup></i>	<i>G</i>
		基本尺寸	偏差	基本尺寸	偏差	约	基本尺寸	偏差	基本尺寸	偏差	基本尺寸	偏差	最小	最大	最大	最大	最大	
M1	0.25	2		0.55		0.2	0.75		0.32		0.4	±0.05	0.1	1.4	0.1	0.05		
M1.2	0.25	2.3	<sup>0</sup> <sub>-0.3</sub>	0.65		0.25	0.9		0.32	<sup>+0.1</sup> <sub>0</sub>	0.5		0.1	1.6	0.1	0.05		
(M1.4)	0.3	2.6		0.7		0.3	1		0.32		0.55		0.1	1.8	0.15	0.1		
M1.6	0.35	3		0.8		0.35	1.15		0.4		0.65	±0.1	0.1	2	0.15	0.1		
* (M1.7)	0.35	3.2		0.85		0.4	1.25	±0.15	0.4		0.7		0.1	2.1	0.15	0.1		
M2	0.4	3.5		1	±0.1	0.45	1.45		0.6		0.8		0.1	2.6	0.15	0.1		
(M2.2)	0.45	4	<sup>0</sup> <sub>-0.4</sub>	1.15		0.5	1.65		0.6		0.9		0.1	2.8	0.2	0.15		
* (M2.3)	0.4	4		1.15		0.5	1.65		0.6		0.9		0.1	2.9	0.2	0.15		
M2.5	0.45	4.5		1.3		0.6	1.9		0.8	<sup>+0.15</sup> <sub>0</sub>	1	±0.15	0.1	3.1	0.2	0.15		
* (M2.6)	0.45	4.5		1.3		0.6	1.9		0.8		1		0.1	3.2	0.2	0.15		
M3 × 0.5	0.5	5.5		1.5		0.7	2.2		0.8		1.2		0.1	3.6	0.25	0.2		
(M3.5)	0.6	6	<sup>0</sup> <sub>-0.5</sub>	1.75		0.8	2.55	±0.2	1		1.4	±0.2	0.1	4.1	0.25	0.2		
M4 × 0.7	0.7	7		1.9		1	2.9		1		1.55		0.2	4.7	0.3	0.2		
(M4.5)	0.75	8		2.1	±0.15	1.1	3.2		1		1.7	±0.25	0.2	5.2	0.35	0.25		
M5 × 0.8	0.8	9	<sup>0</sup> <sub>-0.6</sub>	2.4		1.2	3.6		1.2		1.9	±0.3	0.2	5.7	0.35	0.25		
M6	1	10.5	<sup>0</sup> <sub>-0.7</sub>	2.8		1.5	4.3	±0.3	1.2	<sup>+0.2</sup> <sub>0</sub>	2.3	±0.4	0.25	6.8	0.4	0.3		
M8	1.25	14	<sup>0</sup> <sub>-0.8</sub>	3.7	±0.2	2	5.7		1.6		3	±0.5	0.4	9.2	0.5	0.4		